

Pharmacokinetics of Gemcitabine and Its Metabolites in Patients with Solid Tumors

Amit Khatri* (1), Richard Brundage (1), Douglas Yee (2, 3), Robert Kratzke (2, 3), Mark Kirstein (1, 2)

(1) Department of Experimental and Clinical Pharmacology, College of Pharmacy, University of Minnesota, Minneapolis, MN, USA; (2) Comprehensive Cancer Center, University of Minnesota, Minneapolis, MN, USA; (3) Department of Medicine, University of Minnesota, MN, USA

INTRODUCTION

- Gemcitabine (2',2'-difluorodeoxycytidine, dFdC) is a nucleoside analogue.
- Approved for treatment of pancreatic, non-small cell lung (NSCLC), breast, and ovarian cancers.
- Most commonly administered as a 30 min infusion.
- Toxicities associated with gemcitabine include hepatotoxicity, neutropenia, thrombocytopenia, and rarely, pulmonary toxicity.
- Gemcitabine (>95%) metabolized by plasma and liver cytidine deaminase to form inactive 2',2'-difluorodeoxyuridine (dFdU). It also gets metabolized to di- and tri-phosphate metabolites intracellularly, as shown in Figure 1.
- Gemcitabine clearance varies up to 30-fold between subjects receiving similar dosages.
- dFdCTP exposure has only been partially characterized – within the first 3 hours of drug administration. Cmax varies up to 12-fold between subjects receiving similar dosages [1].
- Accurate information on total exposure and formation clearance of dFdCTP is lacking. To characterize the relationship between parent, inactive-, and active-metabolites, a comprehensive pharmacokinetic model is needed.

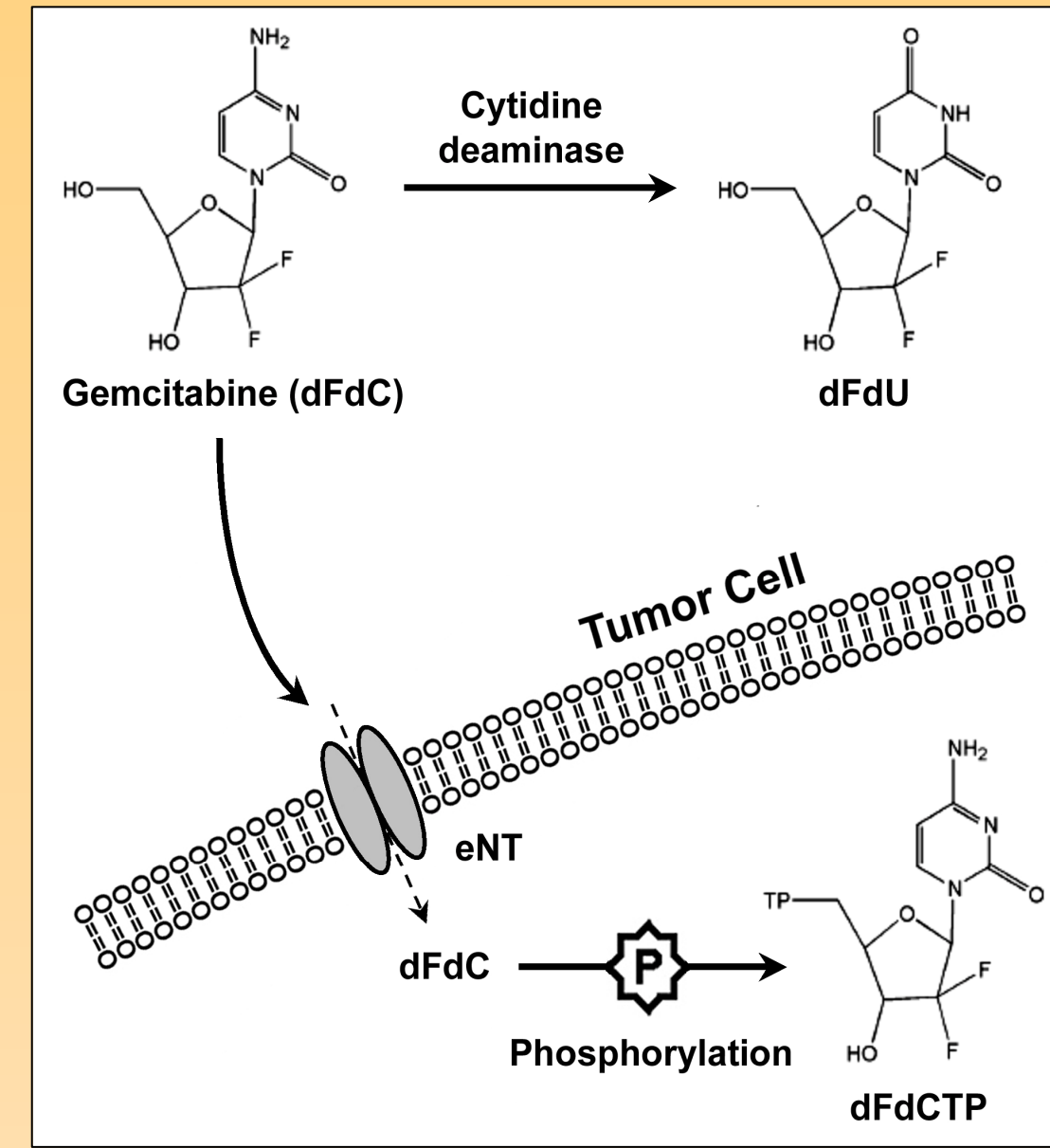

Figure 1. Gemcitabine metabolic pathway

OBJECTIVES

- To characterize gemcitabine and metabolite pharmacokinetics.
- To identify factors associated with gemcitabine pharmacokinetic variability.

METHODS

Study Design

- Human subjects with solid tumors ≥ 18 years of age and receiving gemcitabine are being recruited to participate in this study.
- Demographics, concurrent medications, genomic DNA, and toxicity data are being collected. Plasma is being collected to measure gemcitabine and dFdU, and peripheral blood mononuclear cells (PBMC's) to measure intracellular dFdCTP.
- Pharmacokinetic sampling of plasma and PBMC's is at the following times: pre-dose, 5, 15, 30, 45 min, and 1.25, 1.5, 2, 6, 24, 48, and 72 hr after the end of infusion.
- Gemcitabine, dFdU, and dFdCTP are measured with validated UV-HPLC assays [2].

Pharmacokinetic Analysis

- Pharmacokinetics analysis was done by standard two stage (STS) approach with simultaneous analysis of parent and metabolite data. Figure 2 shows the compartmental pharmacokinetic model used for the analysis.
- Parameter estimation - weighted least squares regression analysis using ADAPT-II program [3]. Weighting is done by inverse of the analytical assay variance.
- One and two-compartments for gemcitabine and up to three compartments for the metabolites (dFdU and dFdCTP) were tested during model fitting.
- Model Selection Criterion - CV of the parameter estimates, AIC, and residual plots of standardized residual versus time and predicted concentrations.
- Gemcitabine clearance through excretion (as parent molecule) was fixed to 10 L/hr, which is about 5% of the reported literature value of total clearance of 185 L/hr [4].
- The terminal elimination half-life for gemcitabine, dFdU and dFdCTP were estimated as $0.693/\lambda$, where λ is the absolute value of the slope of the terminal elimination phase.

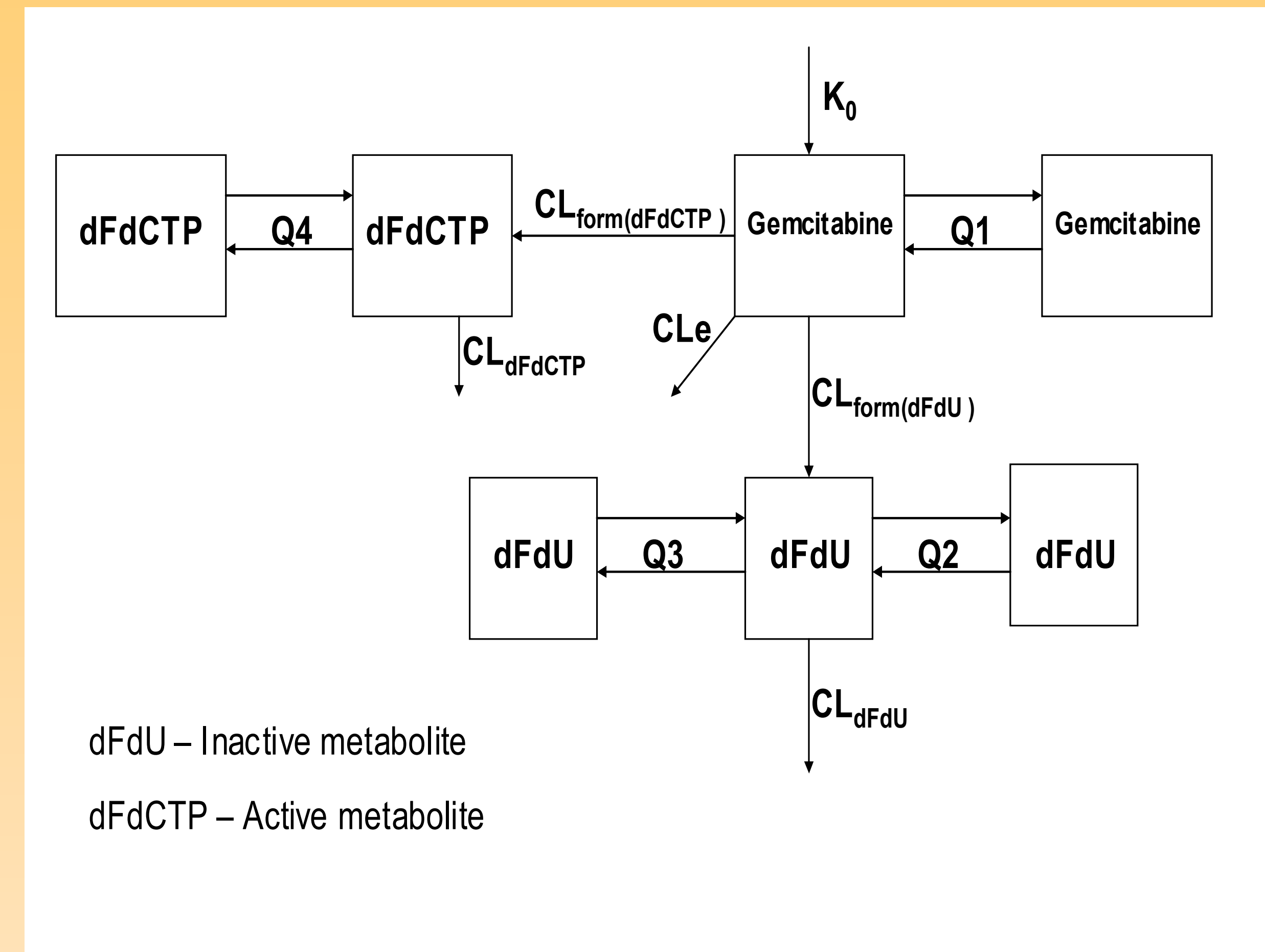

Figure 2. The compartmental pharmacokinetic model for gemcitabine, dFdU and dFdCTP consists of formation CL of dFdU ($CL_{form(dFdU)}$), formation CL of dFdCTP ($CL_{form(dFdCTP)}$), excretory CL of gemcitabine (CLE), elimination CL of dFdU (CL_{dFdU}), elimination CL of dFdCTP (CL_{dFdCTP}), inter-compartmental clearances (Q1, Q2, Q3 and Q4) and volume of distribution of the different compartments.

RESULTS

- 10 Females and 12 Males enrolled. The mean age is 61 years (range 20 to 87 years).
- Gemcitabine doses ranged from 600 to 1200 mg/m². Three patients received gemcitabine as a 90-min infusion and the rest as a 30-min infusion.
- The pharmacokinetic model describing the concentration time profile of most of the patients consisted of 1 compartment for gemcitabine, 3 compartments for dFdU and 2 compartments for dFdCTP. The mean, SD and BSV-CV of the pharmacokinetic parameters of gemcitabine, dFdU and dFdCTP are summarized in the tables below.
- A higher gemcitabine infusion rate is associated with lower formation clearance of dFdCTP ($r=-0.76$).

Pharmacokinetic parameters of gemcitabine, dFdU and dFdCTP

	Gemcitabine				dFdU					
	CL	Vss	AUC _{0-inf}	T _{1/2}	CL _{form(dFdU)}	Vss	CL _{dFdU}	AUC _{0-inf}	T _{1/2-γ}	
	L/hr	L	μmol-hr/L	min	L/hr	L	L/hr	μmol-hr/L	Hr	
Mean	487.2	175.9	16.6	15.1	474.2	196.2	6.9	1414.6	21.5	
SD	183.8	99.3	7.9	7.0	182.4	69.4	4.1	1138.8	11.6	
BSV-CV	37.7	56.5	47.5	46.7	38.5	35.4	59.3	80.5	53.9	

	dFdCTP			
	CL _{form(dFdCTP)}	CL _{dFdCTP}	AUC _{0-inf}	T _{1/2-β}
	L/hr	10 ⁶ cells/Hr	μmol-hr/10 ⁶ cells	Hr
Mean	3.05	0.19	242.1	8.37
SD	2.76	0.191	150.6	11.4
BSV-CV	90.7	100.4	62.2	135.8

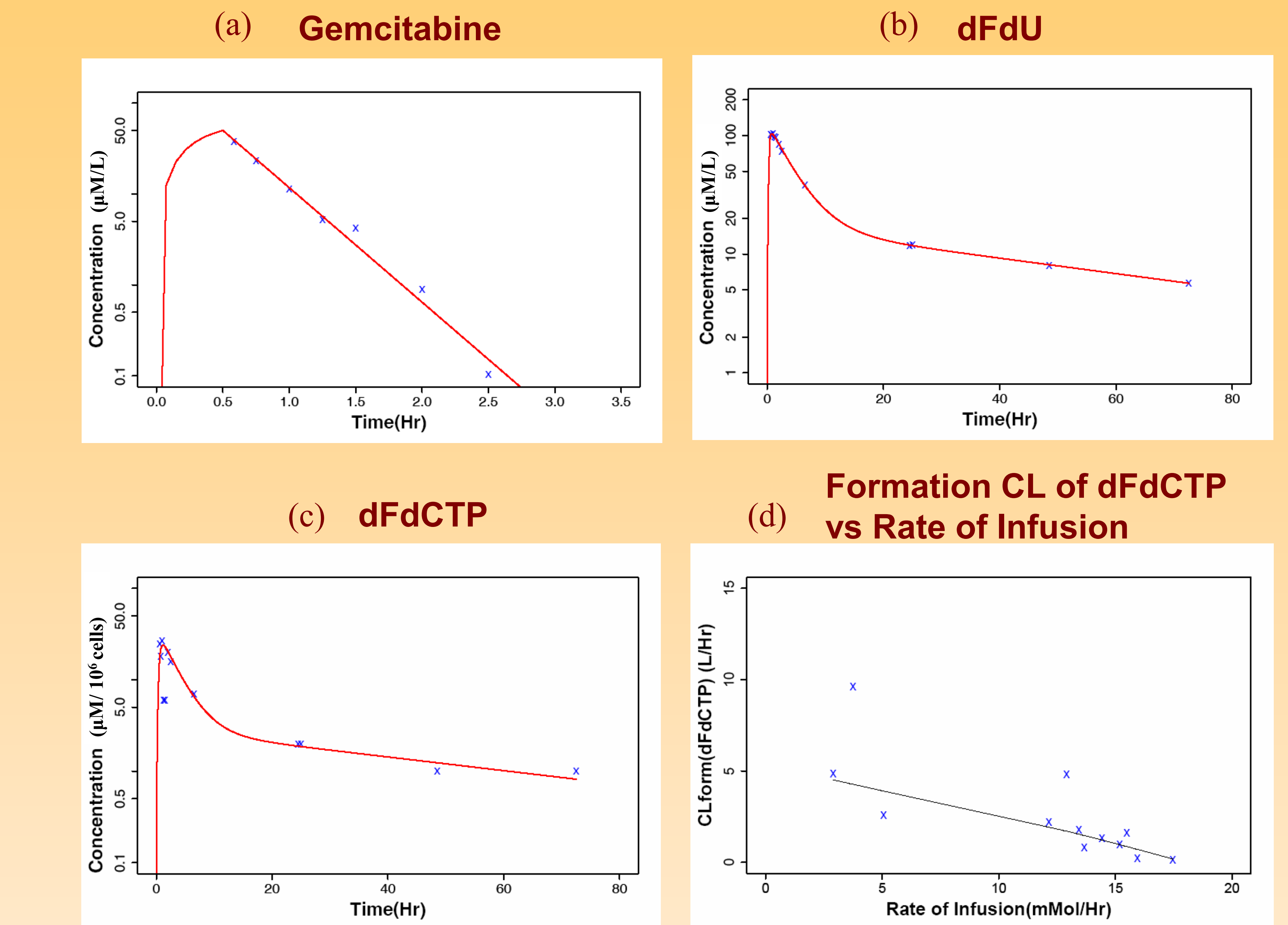

Figure 3. Observed and predicted concentrations versus time plots of (a) gemcitabine, (b) dFdU and (c) dFdCTP in a representative patient who received 1000 mg/m² of gemcitabine over 30-min. Figure 2(d) represents the relationship between formation CL of dFdCTP ($CL_{form(dFdCTP)}$) and rate of gemcitabine infusion.

CONCLUSIONS

To our knowledge, this study is first to evaluate the formation clearance of the active metabolite of gemcitabine. Pharmacokinetic parameters of gemcitabine and its metabolites are consistent with those reported in the literature. Decrease in the formation of dFdCTP at higher infusion rate is consistent with the literature and could be due to the saturation of transporters required for the transport of gemcitabine intracellularly or saturation of its metabolism by deoxycytidine kinase.

FUTURE DIRECTIONS

Population pharmacokinetic analysis of a larger data set to identify patient specific covariates affecting the pharmacokinetics of gemcitabine and its metabolites.

REFERENCES

- Tempero M, Plunkett W, Ruiz Van Haperen V, Hainsworth J, Hochster H, Lenzi R and Abbruzzese J. Randomized phase II comparison of dose-intense gemcitabine: thirty-minute infusion and fixed dose rate infusion in patients with pancreatic adenocarcinoma. J Clin Oncol. 2003 Sep 15;21(18):3402-8.
- Kirstein MN, Hassan I, Guire DE, Weller DR, Dagit JW, Fisher JE and Remmel RP. High-performance liquid chromatographic method for the determination of gemcitabine and 2',2'-difluorodeoxyuridine in plasma and tissue culture media. J Chromatogr B Analyt Technol Biomed Life Sci. 2006 May 1;835(1-2):136-42.
- D'Argenio D, and Schumitzky A. 1997. ADAPT II user's guide: pharmacokinetic/pharmacodynamic system analysis software. Biomedical Simulations Resource, Los Angeles, CA.
- Prescribing information of Gemzar, 2007, Eli Lilly and Company, USA.