

## Title: Effects of Probenecid on the Pharmacokinetics of the Neuraminidase Inhibitor Oseltamivir

Authors: Ronald Gieschke\* (1), Craig Rayner (1), Lauren Boak (1), Pascal Chanu(1), Niclas Jonsson(2)

Institutions: (1) F. Hoffmann-La Roche, Clinical Development, Basel, Switzerland; (2) Exprimov NV, Mechelen, Belgium

**Objectives:** To describe the population pharmacokinetics of the oral neuraminidase inhibitor oseltamivir phosphate (OP) and its active metabolite, oseltamivir carboxylate (OC) in adult humans and to investigate by simulation potential oseltamivir dose sparing effects when combined with probenecid (500mg/6 hourly) known to inhibit OC excretion [1].

**Methods:** Data from a total of 96 subjects, who received various dosages of oral and i.v. oseltamivir either in single- or repeated-dose regimens in four separate studies, and for whom rich PK data was available, were used for the development of the oseltamivir population PK model. Single dose data from 19 subjects in a fifth study, which included an OP arm and an OP + probenecid arm, were used to analyze the effect of probenecid co-administration on the PK of oseltamivir. Model development was performed using non-linear mixed-effect modeling within the program NONMEM (version VI, Level 1.0). All oseltamivir PK data were log-transformed and either the FO or the FOCE method was used for parameter estimation.

As outlined in Figure 1, the population PK model was built in five steps. For the first step, a model was fit to the PK data of OC in 25 subjects following OC administration of a single 150 mg IV dose. Next, OP concentration data derived from 32 subjects administered a range of IV single doses of OP (15 mg, 45 mg, 105 mg) were modeled. In the third step, the disposition of both OP and OC, modeled in the first two steps, were combined and characterized. The fourth step involved incorporation of oral PK data from 48 subjects administered increasing single doses of OP (50 mg, 100 mg, 200 mg, 500 mg and 1000 mg. In the fifth step of model building, multiple dose PK data of oral OP (50 mg, 100 mg, 200 mg, and 500 mg) in 32 subjects were described. Concentration data from a single 150 mg oral dose study in 20 patients were added to the final PK model.

**Figure 1.** Flow chart illustrating the development of the final population PK model for oseltamivir. Each number reflects the subset of data and step in the modeling process leading to the characterization of the structural population pharmacokinetic model (P: Prodrug, M: Metabolite)

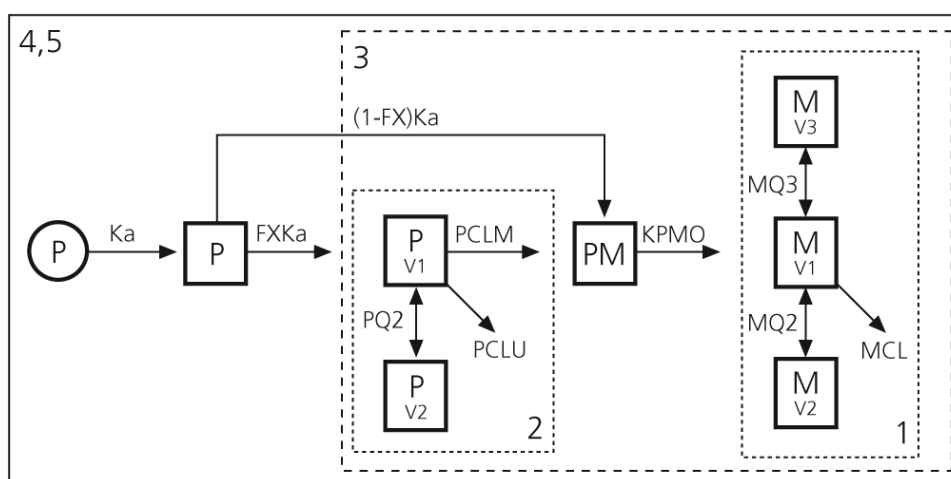

The effect of probenecid on the pharmacokinetics of oseltamivir was evaluated based on the log likelihood ratio test using stepwise inclusion (nominal  $P$ -value 0.05) followed by stepwise deletion (nominal  $P$ -value 0.01) of covariates. Through simulation from the final PK model, potential dose sparing effects of oseltamivir were explored by comparing the PK of oseltamivir alone at the licensed treatment and prophylaxis doses (75 mg bid

and 75 mg daily) with that of oseltamivir + steady-state probenecid, where either the oseltamivir dose or its administration frequency is halved.

**Results:** The final population PK consisted of seven compartments; two for OP disposition, three for OC disposition, an OP-OC metabolism compartment to describe the (rate-limiting) conversion of OP to OC, and a compartment for first-pass metabolism, from which part of an oral OP dose enters the OP central compartment or bypasses OP disposition and enters the OP-OC metabolism compartment directly (Figure 1). Population PK parameters for OP and OC were estimated with high precision; relative standard errors (SE) were <34% for all fixed and random effects parameters. Estimated model parameters were consistent with results reported by He et al [2].

Lower unit dose simulations: Whether given bid or daily (treatment-related or prophylactically), a reduced oseltamivir dose (45 mg) combined with probenecid resulted in OC  $C_{max}$  and  $C_{min}$  values similar to or greater than those for the licensed oseltamivir-alone regimens. Similar simulations with a 30 mg oseltamivir dose produced  $C_{max}$ , median plasma concentration, and AUC values for OC that were lower than those of the licensed doses alone, although  $C_{min}$  levels were similar.

Interval extension simulations: Longer between-dose intervals (daily or every other day) in the presence of probenecid resulted in markedly lower  $C_{min}$  values for OC at the end of the extended dosing intervals compared to the oseltamivir-alone scenarios (bid or daily).

**Conclusions:** Probenecid plus oseltamivir 45mg achieved the pharmacokinetic parameters expected of oseltamivir alone, but combination with oseltamivir 30mg and dose interval extension approaches did not. An oseltamivir-probenecid combination may compromise tolerability and enhance the potential for drug interactions. Increased dosing requirements may also affect compliance and the attainment of optimal oseltamivir exposure, potentially facilitating the emergence of viral strains with reduced susceptibility to oseltamivir. These factors, set alongside increased capacity for oseltamivir production, should be carefully considered before an oseltamivir-probenecid combination is employed.

#### **References:**

- [1] Hill, G. et al. The anti-influenza drug oseltamivir exhibits low potential to induce pharmacokinetic drug interactions via renal secretion-correlation of in vivo and in vitro studies. *Drug Metab. Dispos.* 30, 13–19 (2002)
- [2] He, G., Massarella, J., Ward, P. Clinical pharmacokinetics of the prodrug oseltamivir and its active metabolite Ro 64-0802. *Clin. Pharmacokinet.* 37, 471–484 (1999)